

MM70 Hand-Held Moisture and Temperature Meter for Spot-Checking in Oil



The MM70 is an ideal tool for the preventive maintenance of oil-filled systems. The water activity measurement indicates the margin to free water formation, which causes severe problems in lubrication systems.

The Vaisala HUMICAP® Hand-held Moisture Meter for Oil MM70 enables reliable detection of moisture in oil.

In-line process checking through ball valve

The probe can be inserted directly into the process pipe through a ball valve without draining the oil in the system.

Water activity measurement

The MM70 measures moisture in oil in terms of the water activity (a_w) and temperature (T). Water activity directly indicates whether there is a risk of free water formation. The measurement is independent of oil type, age and temperature.

ppm calculation included

The MM70 has an embedded model for expressing moisture as ppm in mineral transformer oil. The customer can enter up to three other oil models into the meter's memory.

Numerical and graphical display

The MM70 features a multilingual, menu-based user interface and a backlit LCD display. The measurement parameters can be numerically and graphically displayed and logged into the meter's memory at the same time. An analog output option is also available.

Connection to PC

The optional MI70 Link Windows® software is used to transfer logged data and real time measurement data from the MM70 to a PC.

Proven Vaisala HUMICAP® technology

The MM70 incorporates the latest generation of the Vaisala HUMICAP® Sensor, developed for demanding moisture measurements in liquid hydrocarbons. The sensor's excellent chemical tolerance provides accurate and reliable measurement over the measurement range.

Features/Benefits

- Measurement independent of oil type, age and temperature
- In-line process checking through ball valve, no need to drain the oil
- Rugged and reliable construction
- Excellent pressure and temperature tolerance
- Data can be logged and transferred to a PC
- Vaisala HUMICAP® Sensor - proven field performance since 1973
- Compatible with Vaisala's fixed oil moisture instruments
- Temporary outdoor logging possible with carrying case
- No reference oil needed for recalibration

Speedy service - once a year

The meter can be recalibrated by sending the probe to Vaisala Service, or customers can calibrate the instrument themselves using a standard relative humidity calibration.

Multi-probe operation

One or two probes can be connected simultaneously. Maintenance teams can use additional Vaisala dewpoint or relative humidity probes for other tasks. For example, a dewpoint probe is ideal for checking the moisture inside washed and dried oil tanks.

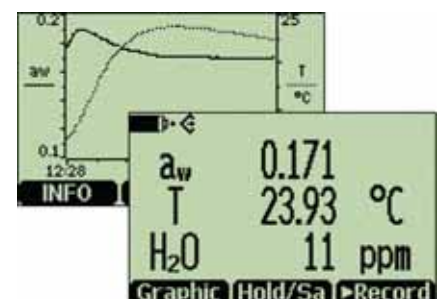

Display featuring selectable parameters in numerical and graphical format.

Performance

Water activity

Measurement range	0...1 aw
Accuracy (including nonlinearity, hysteresis and repeatability) When calibrated against salt solutions (ASTM E104-85):	
0...0.9	±0.02
0.9...1.0	±0.03
Maximum achievable accuracy when calibrated against high-quality, certified humidity standards:	
0...0.9	±0.01
0.9...1.0	±0.02

Response time (90%) at +20 °C (+68 °F) in still oil (with stainless steel filter)	10 min.
Sensor	Vaisala HUMICAP®
Recommended recalibration interval	1 year

Temperature

Measurement range	-40...+100 °C (-40...+212 °F)
Typical accuracy at +20 °C	±0.2 °C (±0.36 °F)
Typical temperature dependence of electronics	±0.005 °C/°C (±0.005 °F/°F)
Sensor	Pt 100 IEC 751 1/3 class B
Typical long-term stability	better than 0.01 aw / year

Operating environment

Probe

Operating temperature range for electronics	-40...+60 °C (-40...+140 °F)
Operating pressure range	max. 20 bar
during installation through ball valve	max. 10 bar
Oil flow range	max. 1 m/s

Indicator

Operating temperature range	-10...+40 °C (+14...+104 °F)
Operating humidity range	non-condensing

Electromagnetic compatibility

Complies with EMC standard EN61326-1:1997 + Am1:1998 + Am2:2001; Electrical equipment for measurement, control and laboratory use - EMC requirements: Portable test and measurement.

Inputs and outputs

Power supply	Rechargeable NiMH battery pack with AC-POWER or 4xAA-size alkalines, type IEC LR6
Battery operation time	
continuous use	48 h typical at +20 °C (+68 F)
datalogging use	up to 31 days
Menu languages	English, French, Spanish, German, Swedish, Finnish
Display	LCD with backlight, graphic trend display of any parameter, character height up to 16 mm
Analog output	0...1 VDC
Output resolution	0.6 mV
Data interface	RS-232
Data logging capacity	2700 points
Alarm	audible alarm function

Mechanics

Probe

Housing classification	IP65 (NEMA 4)
Housing material	ABS/PC blend

Probe material	Stainless steel (AISI316L)
Cable length between probe and indicator	1.9 m, 10 m extension available
Weight	506 g
Indicator	
Housing classification	IP54
Weight	400 g
Probe inputs	1 or 2

Options and accessories

Carrying case	MI70CASE2
Ball valve set (incl. fitting body & blanking plug)	HMP228BVS
Probe cable extension, 10 m	213017SP
Transmitter connection cables for	
HMP228	27159ZZ
MMT318	DRW216050
Analog output cable	27168ZZ
Windows® software, includes PC connection cable	MI70LINK
Sensor protection	HM47453SP
Dewpoint measurement probes	DMP74A/B
Relative humidity measurement probes	HMP75, HMP76, HMP77

Dimensions

Dimensions in mm (inches)

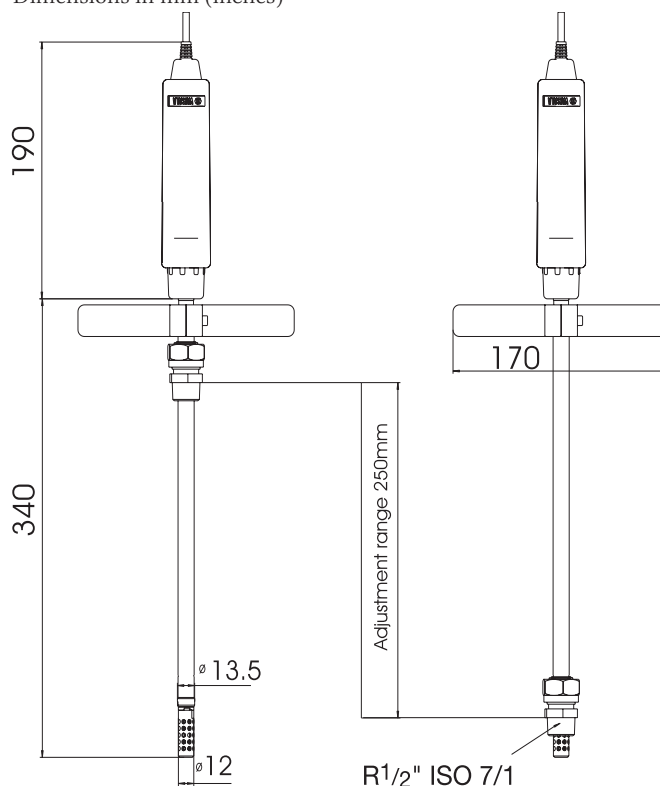

HUMICAP® is a registered trademark of Vaisala.
Specifications subject to change without prior notice.
©Vaisala Oyj

